

**THORN**  
LIGHTING



# ARENA SYMPHONY

Innovative LED luminaire with sound absorbing  
features to minimise reverberation echoes



# CREATING THE PERFECT LEARNING ENVIRONMENT

Creating the perfect learning environment is key to maximising learning potential of students. Controlling and optimising the lighting and acoustic properties of our learning environment can help stimulate their learning.



Education



Office



# MAXIMISE STUDENT LEARNING

## WITH OPTIMUM LIGHTING AND ACOUSTICS

Research\* shows that controlling and optimising lighting, acoustics and the environment can help stimulate learning. Creating the perfect classroom environment is therefore essential for helping to maximise student's learning potential. Good quality lighting increases student communication and participation, and makes it easier to see the

whiteboard. At the same time, effective acoustic control makes it easier to listen and understand while removing the need for shouting. As well as facilitating learning, both lighting and acoustics are important for ensuring the comfort and wellbeing of students.

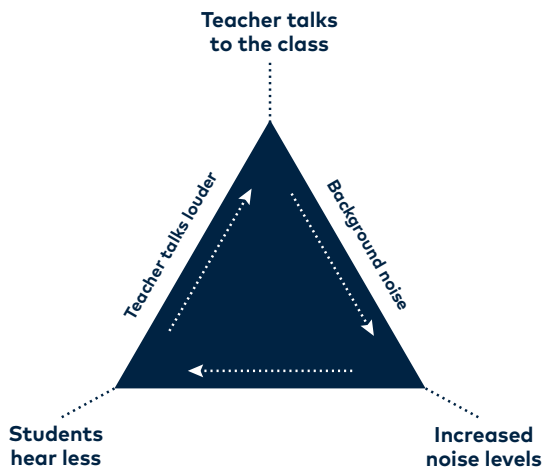

### STANDARDS REQUIRE

As specified by the UK's Building Bulletin 93 (BB93), Germany's DIN 1804 and the international EN ISO 3382-3, the maximum reverberation time for primary and secondary school classrooms is < 0.6 and < 0.8 seconds respectively.

Country	Standard/ Guideline	Year	Required T (s)	Occupancy
Denmark	BR2010	2010	$\leq 0.6$	Furnished unoccupied
France	Arrete du 25 avril 2003	2003	$V < 250\text{m}^3: 0.4 \leq T \leq 0.8$ $V < 250\text{m}^3: 0.6 \leq T \leq 1.2$	Furnished unoccupied
Germany	DIN 18041:2004	2004	$T_{\text{soil}} = 0.32\text{s} \log V - 0.17$ ( $V = 100^3 \rightarrow T_{\text{soil}} = 0.47\text{s}$ ) ( $V = 250^3 \rightarrow T_{\text{soil}} = 0.60\text{s}$ )	Fully occupied
Norway	NS8175:2012	2012	$\leq 0.5$ (Class C)	Furnished unoccupied
Spain	CTE DB-HR	2009	$V \leq 350^3\text{m}^3: \leq 0.5$	Fully occupied
UK	BB93	2003	Nursery & Primary: $\leq 0.6$ Secondary: $\leq 0.8$	Unfurnished unoccupied

## THE IMPORTANCE OF REVERBERATION TIME IN CLASSROOMS

Reverberation time is the time it takes for sound to decay 60 decibels from its initial level. In a more reflective room, such as a concert hall, it will take longer for the sound to die away and the room is said to be live. In a very absorbent room, such as a carefully designed lecture theatre, the sound will die away quickly and the room is described as acoustically dead. Large rooms and those with hard surfaces and décor of poor absorption qualities will naturally have longer reverberation times. However, it is important to maintain the maximum

reverberation time to < 0.6 seconds for primary school or small classrooms and < 0.8 seconds for secondary/larger school classrooms. Exact targets vary slightly by country.

Echoes blur the teacher's voice and make it harder for students to hear. Students react by talking louder, which creates a vicious circle of noise. What may appear to be an unruly class may infact be poor acoustic design. Either way the learning outcomes are impacted.

\*Daylighting in Schools, Herschong Mahone Group, 1999





Higher ceilings for daylight ingress

Suspended, so false ceiling not required

Daylight through large windows

Solid walls

Solid floors

# CLASSROOM ARCHITECTURE TRENDS

## EXPOSED CONCRETE CEILINGS, HARD FLOORS AND MORE NATURAL DAYLIGHT

### MODERN TRENDS ARE CREATING POOR SOUND ABSORPTION

The modern classroom has moved away from conventional suspended ceilings in favour of exposed concrete. As well as saving on purchasing and installation costs, exposed concrete ceilings have a high thermal mass to keep the classroom temperature stable and reduce the need for active heating and cooling, offer higher ceilings for daylight ingress improving learning rates and reducing the need for electric light. However, exposed concrete ceilings coupled with solid floors and increased glazed areas leave classrooms with poor sound absorption and multiple echoes.

### MEETING KEY REQUIREMENTS

To ensure compliance with the strict reverberation guidelines of BB93, DIN 1804 and EN ISO 3382-3, one of the following two actions can be taken:

- Add extra acoustic absorption to walls
- Incorporate acoustic absorbing material into the luminaire

Incorporating acoustic absorbing material into the luminaire is desirable because it is quicker and easier to install, creates just one supplier for both acoustics and lighting, improves bass frequency sound absorption and reduces overall the required surface area for acoustic material within the room.

### THE IMPORTANCE OF CLASSROOM DAYLIGHT

Research of 21000 pupils over three countries has found high levels of daylight resulted in:

- High improvements in learning rates
- Increased attendance
- 20 % higher results in reading and maths

This was the result of:

- Higher levels of illuminance
- Improved visibility
- Improved melatonin production
- Better colour rendering

How to achieve more daylight:

- Increase window size
- Remove false ceilings

# ARENA SYMPHONY

## SOUND ABSORBING PANELS MINIMISE CLASSROOM REVERBERATION

Fully compliant with the European acoustic regulations and lighting requirements EN 12464 Arena Symphony is a complete, single solution for absorbing sound.

Using sound absorbing panels and high performance LEDs, Arena Symphony creates quieter, brighter and more comfortable environments to improve communication and maximise learning.

### OPTIMUM ACOUSTIC PERFORMANCE USING LESS SURFACE AREA

Arena Symphony is suspended to ensure optimum acoustic performance with both sides of the luminaire benefiting from acoustic material for maximum sound absorption efficiency. Arena Symphony requires approximately half the area of a wall panel to achieve the same acoustic performance. As a suspended continuous row luminaire Arena Symphony also hides unsightly concrete ceilings and can accommodate other mechanical and electrical services, including sprinklers and smoke alarms.

Arena Symphony is specifically designed for primary and secondary school classrooms with poor sound absorption.

### These include classrooms with:

- Concrete ceilings
- Plasterboard or highly glazed walls
- Solid wood or vinyl flooring

### HIGHER COMPLIANCE, LESS FITTINGS

For a 56 m<sup>2</sup> secondary school classroom Arena Symphony achieves acoustic and lighting standards with just six fittings. This not only makes the luminaire easier, faster and cheaper to install, but also reduces overall costs by using less luminaires.

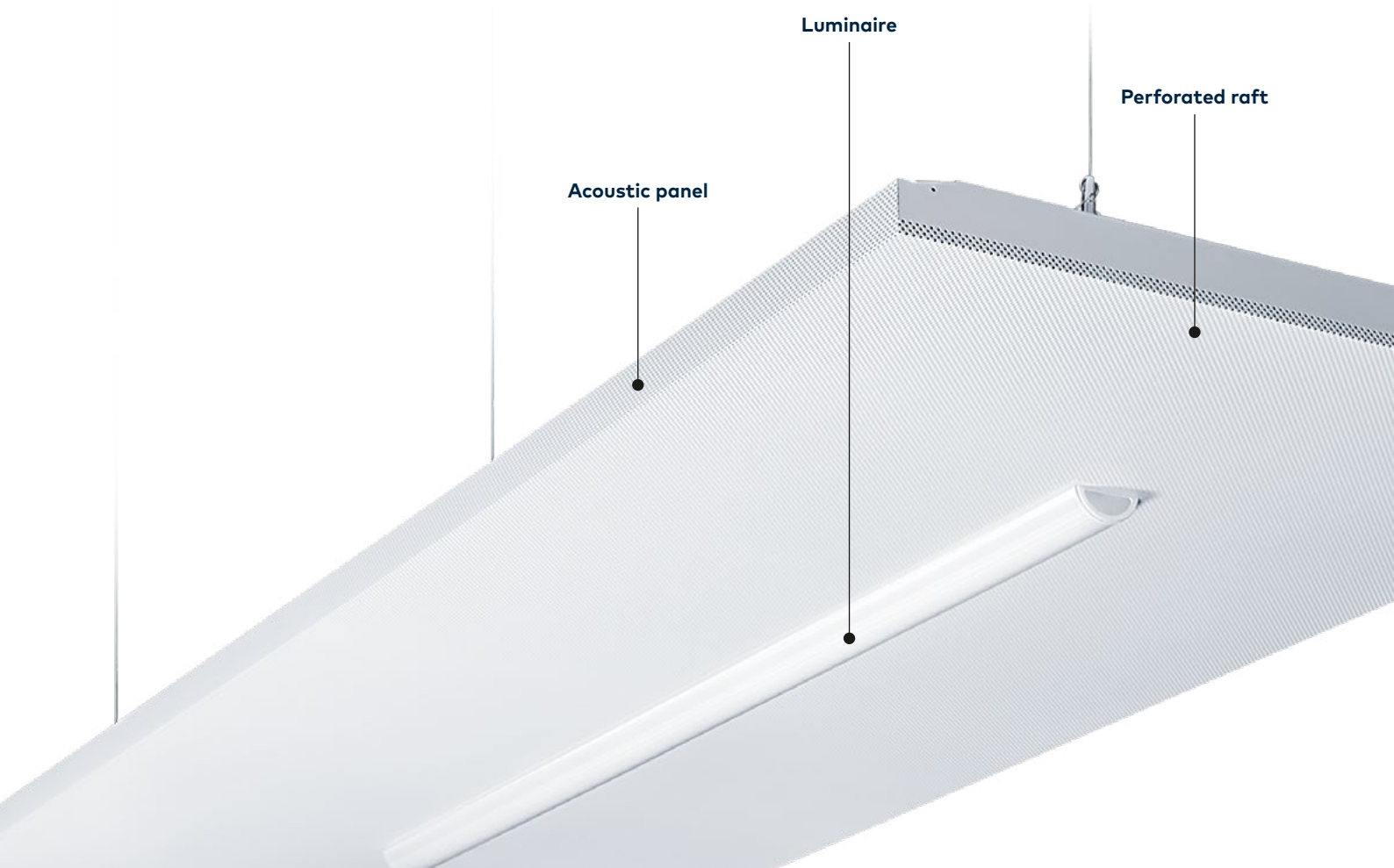



## ARENA SYMPHONY IS FULLY COMPLIANT WITH EUROPEAN ACOUSTIC REGULATIONS

Arena Symphony is designed to comply with European acoustic regulations (measured for an empty classroom) in the worst case scenario, where:

- Walls are finished with plasterboard
- There is an exposed concrete soffit

- Entry to the classroom is via a single timber doorway of area 2 m<sup>2</sup>
- Windows of areas 24 m<sup>2</sup> cover approximately one half of the exterior wall
- Floors have a hard covering such as linoleum or parquet over concrete
- Luminaires are suspended a minimum of 300 mm below the ceiling

## ACOUSTIC PERFORMANCE OF ARENA SYMPHONY IN RELATION TO SOUND FREQUENCY

The sound absorption material in Arena Symphony has been selected to absorb the sound frequencies common in educational spaces. The table and graph show how our acoustic material performs as measured in the laboratory and can be used by an acoustic designer to evaluate the performance of the product in designed spaces.

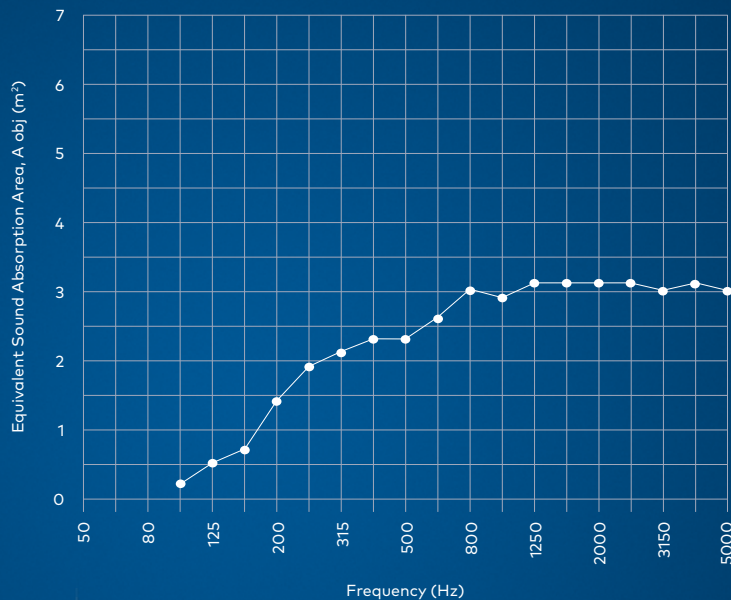

Frequency (Hz)	A obj One Third octave (m <sup>2</sup> )	A obj Octave (m <sup>2</sup> )
50		
63		
80		
100	0.2	
125	0.5	0.5
160	0.7	
200	1.4	
250	1.9	1.8
315	2.1	
400	2.3	
500	2.3	2.4
630	2.6	
800	3.0	
1000	2.9	3.0
1250	3.1	
1600	3.1	
2000	3.1	3.1
2500	3.1	
3150	3.0	
4000	3.1	3.0
5000	3.0	
6300		
8000		
10000		

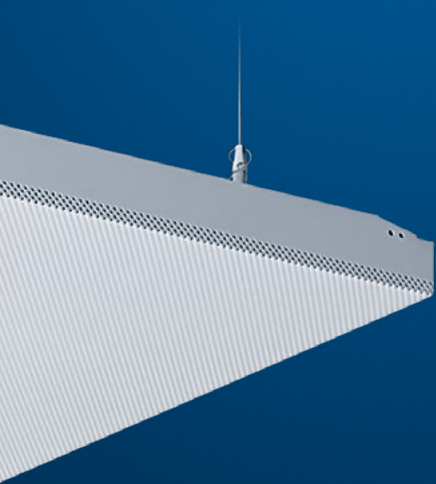

# INSTALLATION POSSIBILITIES

## ARENA SYMPHONY IS EASY TO ORDER AND INSTALL FOR SPEED AND CONVENIENCE

- For quick and simple ordering and installation, Arena Symphony is supplied as a complete out of the box product including the raft, luminaire, four suspension wires and two joining bars and screws.
- Depending on the project requirements, simply order the required infill separately (300, 700, 1200 or 1800 mm).
- No additional accessories are necessary, although a wall bracket can be ordered to directly fix the luminaire to the wall to accommodate smaller classrooms or projects where the power supply and/or DALI signal are coming directly from the wall.
- Arena Symphony benefits from separate packing for the raft, luminaire and joining bar, with all components provided on one pallet.
- The packaging design reduces risk of product damage, reduces packaging waste with more products per pallet, and reduces overall packaging size to reduce space requirements.
- Easier installation because the luminaire is not attached to the raft. Without the luminaire it is less heavy. 2 teams: one person who is doing the ceiling and one installer.

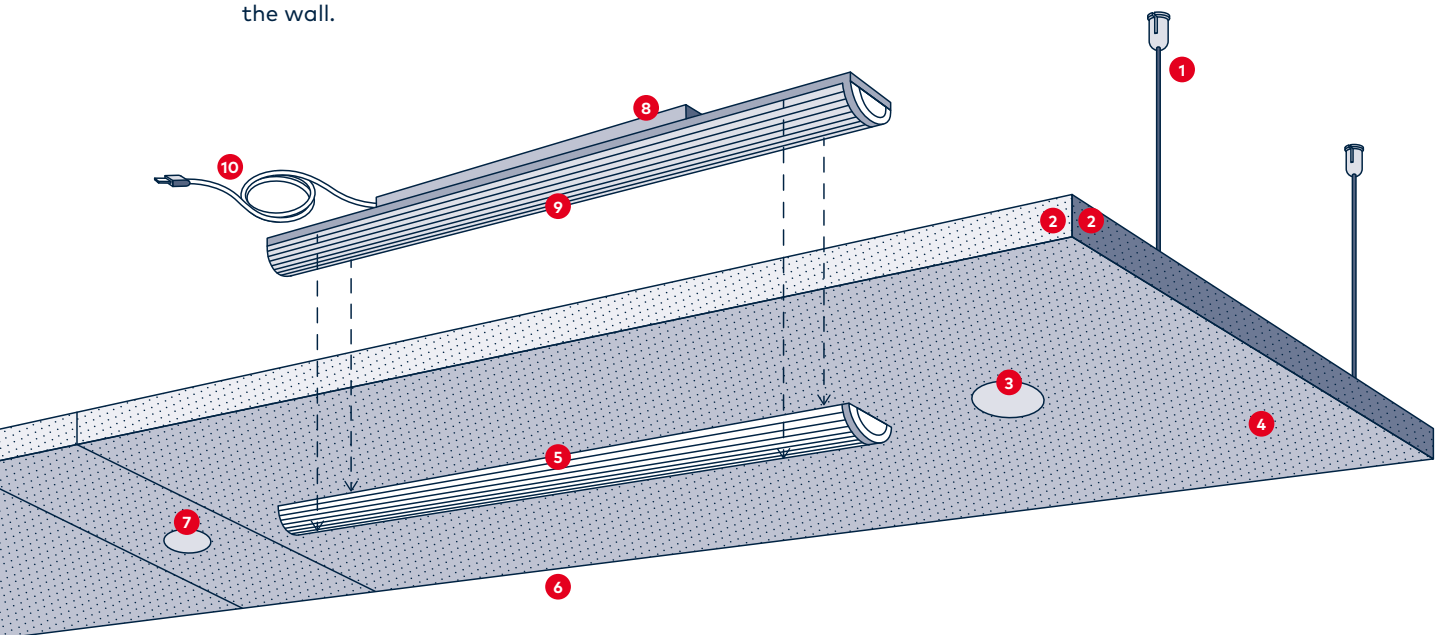

- 1 Suspension wires supplied as standard (1.5 m length)
- 2 Panel sides perforated to maximise acoustic absorption
- 3 Sensor and emergency versions available
- 4 Base: best performing acoustic material used

- 5 Central Optic
- 6 RAL 9010
- 7 Integrated Services via Custom Product Dept.  
**Example:** speaker, sprinkler, wifi etc.
- 8 Quick Wieland 6 pole connector

- 9 **2 optics available:**  
EDP – round prismatic diffuser to allow UGR < 19  
EFL – flat prismatic diffuser UGR < 22
- 10 Infill (300, 700, 1200, 1800 mm)

DISCOVER

# ARENA SYMPHONY

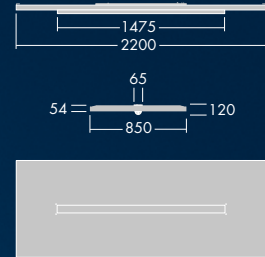
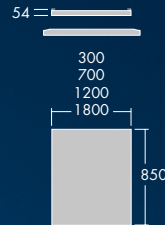

	5000 lm, 6500 lm	
	Up to 128 lm/W	
	4000 K	
	80	
	MacAdams 3	
	EDP (round prismatic diffuser in acrylic)	EFL (flat prismatic diffuser in acrylic)
	< 19	< 19
	<p>Direct – Indirect (69/31)</p>	
	Sound absorbing panels	
	50 000 h L80 @ 25°C	
	Infill panels (300 mm, 700 mm, 1200 mm, 1800 mm), Wall kit, Suspension kit, Bar kit	
	E3, E3TX	
	Fixed output (HF), DALI Dimmable (HFIX), Presence and daylight detector (HFSX)	



## INSTALL IN JUST FOUR SIMPLE STEPS:

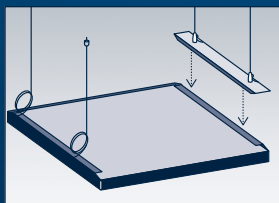

**Step 1:** Prefix the suspension wire on the ceiling and to the joining bar, roughly adjusting the height as necessary.

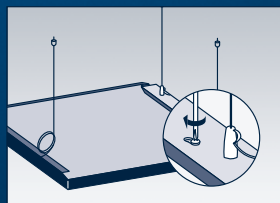

**Step 2:** Pre install the screws on the raft, lift it up and fix it to the joining bar.

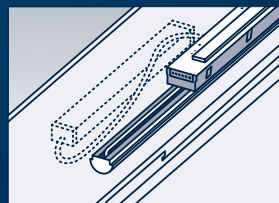

**Step 3:** Insert the luminaire into the raft.

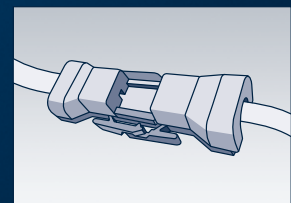

**Step 4:** Connect all luminaires electrically with the pre fixed connector.

# GET IN TOUCH

[www.thornlighting.com/ARNS](http://www.thornlighting.com/ARNS) [www.thornlighting.com/contacts](http://www.thornlighting.com/contacts)



**5 YEAR  
GUARANTEE**

As a globally leading luminaire manufacturer, Thorn Lighting provides a five-year warranty for its complete product range within all European Countries.  
[thornlighting.com/guarantee](http://thornlighting.com/guarantee)

Thorn Lighting is constantly developing and improving its products. All descriptions, illustrations, drawings and specifications in this publication present only general particulars and shall not form part of any contract. The right is reserved to change specifications without prior notification or public announcement. All goods supplied by the company are supplied subject to the company's General Conditions of Sale, a copy of which is available on request. All measurements are in millimetres and weights in kilograms unless otherwise stated.  
07/2021 (INT)

**WE  
MAKE  
LIGHT  
WORK**